

ALL SEASON DECKING **INSTALLATION INSTRUCTIONS**

***We recommend that you read through these step-by-step instructions before you start.
Failure to follow installation instructions will void all existing and implied warranties.***

Notice:

It is the installer's responsibility to determine site-specific structural requirements, and to ensure that the local building code is adhered to prior to construction. An architect, engineer, or local building official should be consulted to clarify local requirements and site-specific details.

Do NOT, under any circumstances, use All Season Decking deck boards for structural framing.

Expansion and Contraction:

Different deck board materials will have unique reactions to temperature and moisture level changes. Wood for example, will expand and contract along the width of the board, while PVC deck boards will be affected along the length of the board. The most significant impact on PVC deck board length occurs when the board is exposed to extreme temperature highs and lows. This being said, please consider the following when installing PVC deck boards to control longitudinal movement:

- Butt joints must be tight, however, if installation takes place below 0°C ensure that a 1/16" gap is left between butt joints for expansion during warmer conditions.
- End boards: maintain a 1/2" gap between end boards and any structures.
- Minimum spacing: maintain 1/4" between boards and any structure, post, or obstruction.
- Cut boards to required finished length and install as soon as possible after receiving material.
- For decks with a surface longer than 20', orient the boards perpendicular to the longest section. E.g.: the boards for a 40' x 12' deck should be installed perpendicular to the 40' section.

Deck Layout

The following details should be taken into consideration for different deck layouts.

Staggered Deck Boards

Blocking on each side of the butt joint is required. The blocking must be secured to the joist with at least four (4) #9 x 3" screws.

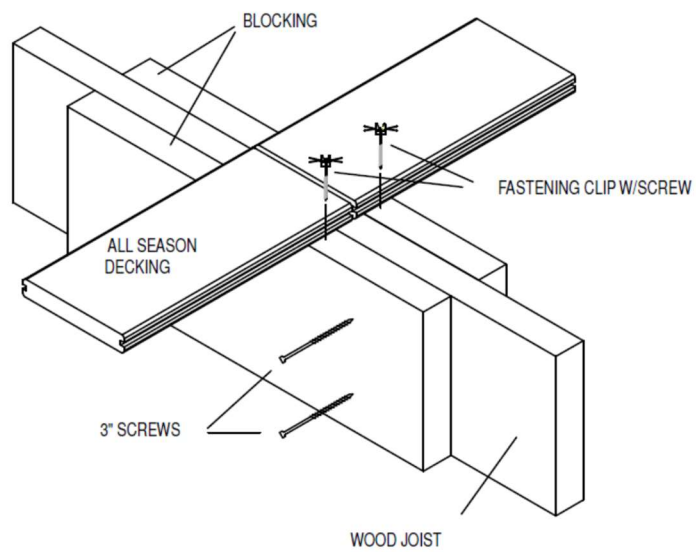
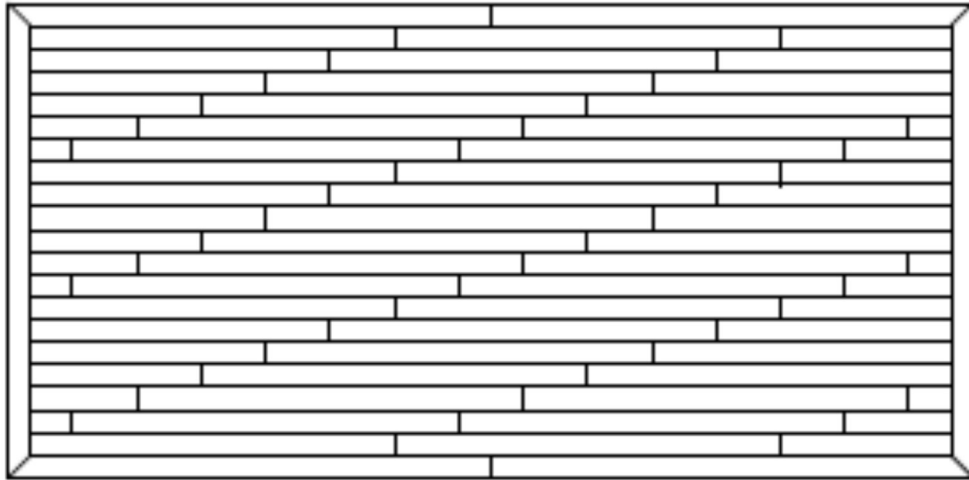

Breaker Board Pattern

The dividing board should be installed perpendicular to the longest section of the deck (see illustration). This butt joint will require the same blocking as listed in the previous section.

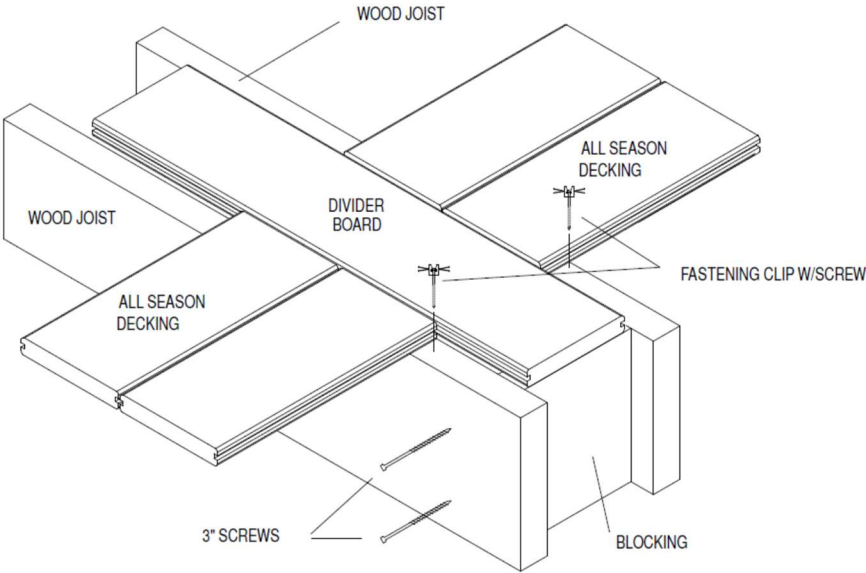
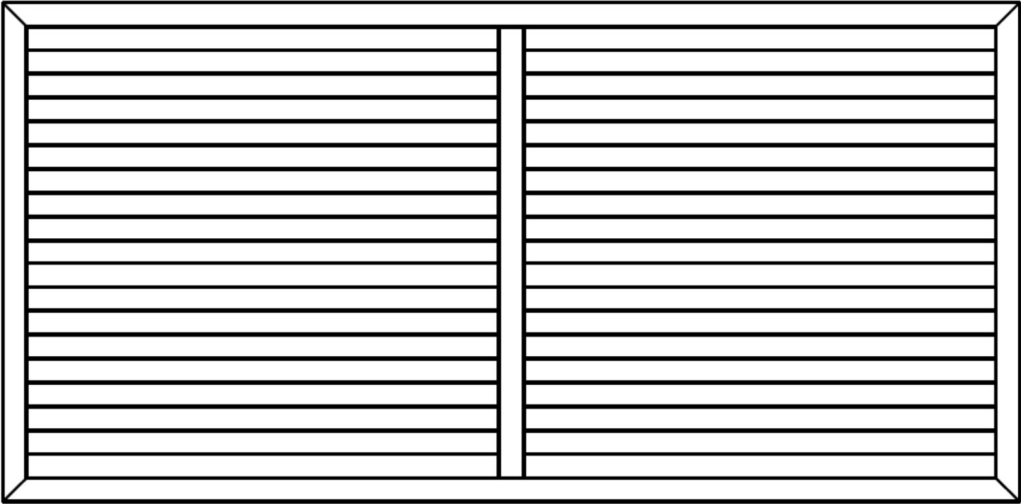

Joist Spacing and Structural Considerations

All Season Decking recommends that SPF-grade pressure-treated lumber be used for deck framing, and that all railings be installed to the deck frame and not the PVC deck boards.

These boards are designed and tested based on 16" O.C. joist spacing, however, they can be installed on 12" O.C. joists if a more rigid walking surface is desired. If the boards are to be installed on a 45°, the joists must be 12" O.C.

Fasteners and Installation Methods

All Season Decking boards can be installed with hidden clips or with hidden deck screws (see illustration below). Surface screws will be required to secure some boards (e.g. end boards, installing replacement boards, and fascia); for these instances most conventional decking screws longer than 1 ½" are sufficient.

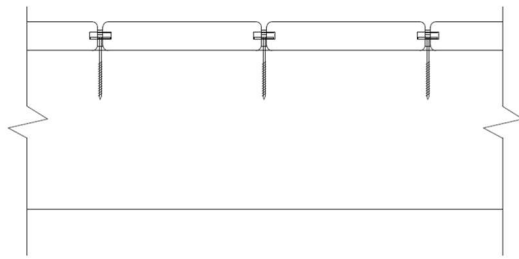

EDGE CLIP FASTENING

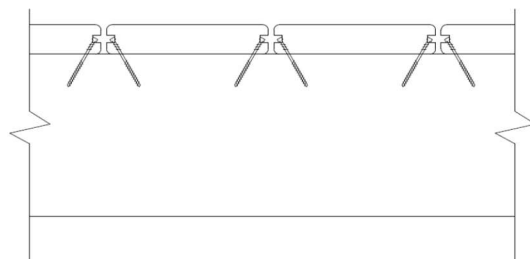

SIDE SCREW FASTENING

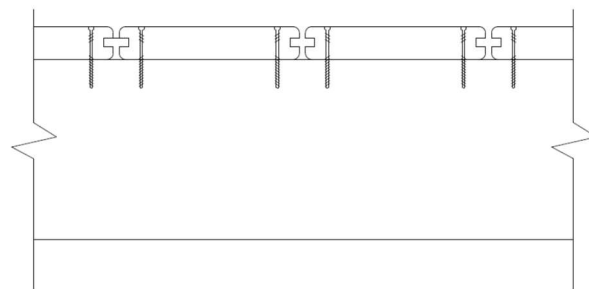

BOARD SURFACE FASTENING

Fascia Board Installation

The following instructions must be followed to ensure correct, secure fascia board installation:

- For sections longer than a full-length board a scarf joint shall be used to continue a section of fascia. PVC contact cement should be applied to the joint.
- Fasten fascia board to rim joist with at least three (3) 1 ½" decking screws.

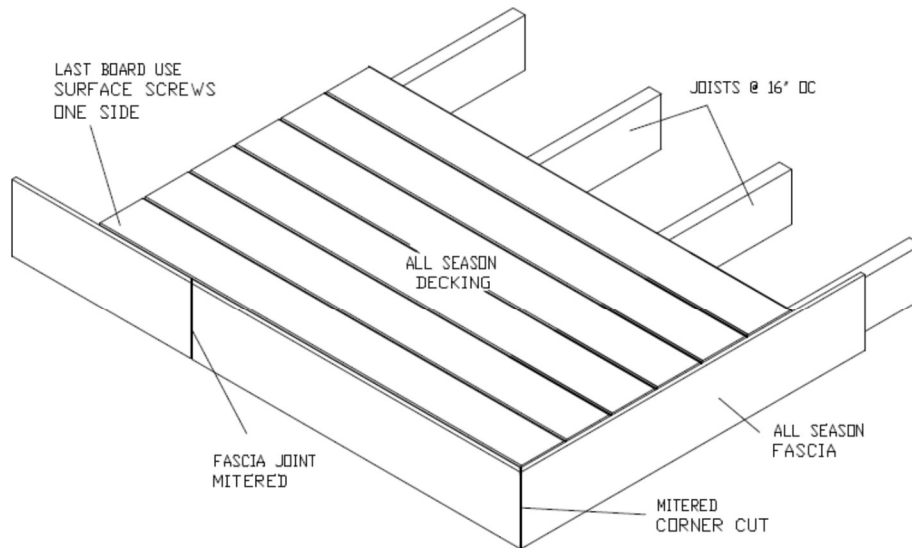
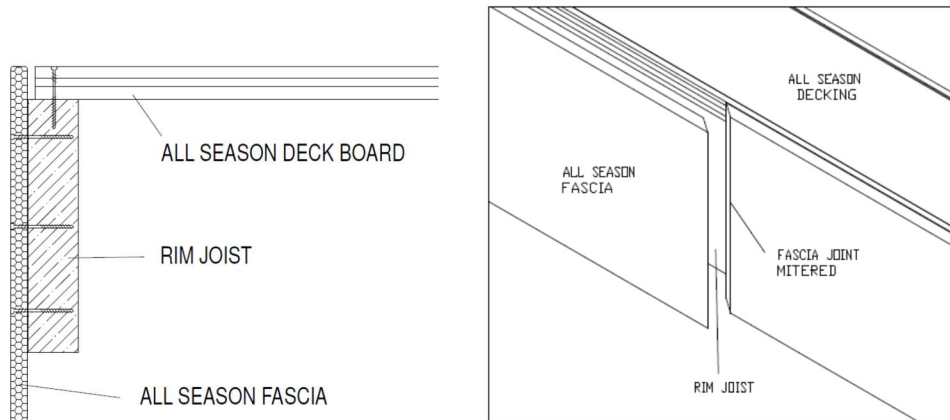

Stairs

Two (2) solid deck boards should be used for a comfortable and secure stair tread, and the fascia for the riser. Do not cantilever any portion of the solid boards for the stair tread. In order to properly secure the fascia riser to the stringer, use two (2) decking screws at 12" O.C. with construction adhesive applied to the back of the fascia board.

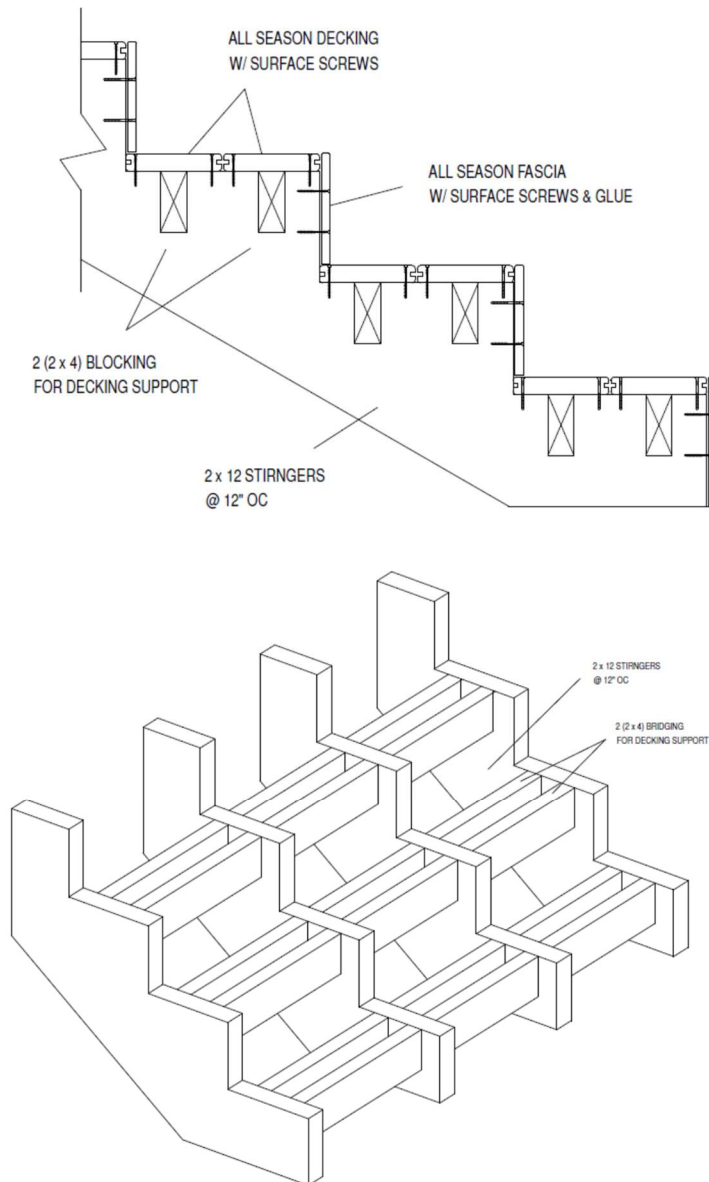

Care and Maintenance

All Season Decking deck boards are designed to require a minimal amount of maintenance. However, as with all outdoor products, some basic steps need to be taken to keep it looking at its best. The following is a list of recommendations that will make sure your deck will look as good as the day it was installed:

- Remove any accumulated debris (e.g. dirt, pollen, fallen leaves, etc...) at least twice per year with a household broom or leaf blower.
- Anything not easily removed with a broom can be cleaned with a mild soap and water mixture and soft-bristled brush. Alternatively, a pressure washer may be used; please ensure that the pressure is set at 1200 psi or lower, and that the nozzle is at least 12" from the face of the board. For the best results spray in the direction of grain.
- Barbeques, fire-pits, and other sources of heat should be placed on a non-rubber or non-vinyl mat to protect the deck boards. Prolonged direct exposure to these materials can discolour the boards.
- Snow should be removed with a non-metallic shovel or stiff-bristled broom. Salt may be used to remove any ice and will have no adverse effect on the boards; salt residue can be removed with a mild soap and water mixture.
- Water containing chlorine from pools or hot tubs will not damage the deck boards.